

Specification

Nominal Voltage	12V	
Nominal Capacity(10HR)	55.0AH	
Dimensions	Length	229±3mm (9.02 inches)
	Width	138±2mm (5.43 inches)
	Container Height	205±3mm (8.07 inches)
	Total Height (with Terminal)	211±3mm (8.31 inches)
Approx Weight	Approx 16.2 kg (35.7lbs)	
Terminal	T6	
Container Material	ABS	
Rated Capacity	57.2 AH/2.86A	(20hr , 1.80V/cell,25°C/77°F)
	55.0 AH/5.50A	(10hr, 1.80V/cell,25°C/77°F)
	47.3 AH/9.46A	(5hr, 1.75V/cell,25°C/77°F)
	42.9 AH/14.3A	(3hr, 1.75V/cell,25°C/77°F)
	33.6 AH/33.6A	(1hr, 1.60V/cell,25°C/77°F)
Max. Discharge Current	660A (5s)	
Internal Resistance	Approx 7.5mΩ	
Operating Temp.Range	Discharge	-15~50°C (5~122°F)
	Charge	0~40°C (32~104°F)
	Storage	-15~40°C (5~104°F)
Nominal Operating Temp. Range	25±3°C (77±5°F)	
Cycle Use	Initial Charging Current less than 16.5A.Voltage	
	14.4V~15.0V at 25°C(77°F)Temp. Coefficient -30mV/°C	
Standby Use	No limit on Initial Charging Current Voltage	
	13.5V~13.8V at 25°C(77°F)Temp. Coefficient -20mV/°C	
Capacity affected by Temperature	40°C (104°F)	103%
	25°C (77°F)	100%
	0°C (32°F)	86%
Self Discharge	TRV LP series batteries may be stored for up to 6 months at 25°C(77°F) and then a freshening charge is required. For higher temperatures the time interval will be shorter.	



Applications

- ◆ All purpose
- ◆ Uninterruptable Power Supply (UPS)
- ◆ Electric Power System (EPS)
- ◆ Emergency backup power supply
- ◆ Emergency light
- ◆ Railway signal
- ◆ Aircraft signal
- ◆ Alarm and security system
- ◆ Electronic apparatus and equipment
- ◆ Communication power supply
- ◆ DC power supply
- ◆ Auto control system



Constant Current Discharge (Amperes) at 25°C (77°F)

F.V/Time	5min	10min	15min	20min	30min	45min	1h	2h	3h	4h	5h	6h	8h	10h	20h
1.85V/cell	94.1	74.0	62.9	52.6	41.8	31.7	25.9	16.5	13.1	10.7	8.60	7.49	6.08	5.19	2.83
1.80V/cell	126.4	94.6	76.0	62.2	49.4	36.8	29.0	18.0	14.1	11.4	9.23	8.03	6.45	5.50	2.86
1.75V/cell	142.5	103.9	83.1	66.9	51.3	38.2	30.4	18.7	14.3	11.6	9.46	8.25	6.56	5.56	2.89
1.70V/cell	156.9	113.3	88.7	70.4	53.3	39.7	31.3	19.4	14.7	11.9	9.71	8.42	6.65	5.61	2.94
1.65V/cell	173.0	122.2	94.3	74.7	56.3	40.7	32.4	20.0	15.3	12.4	9.98	8.61	6.75	5.73	2.98
1.60V/cell	190.8	132.7	100.8	79.6	59.4	42.5	33.6	20.7	15.8	12.7	10.3	8.79	6.82	5.79	3.00

Constant Power Discharge (Watts/cell) at 25°C (77°F)

F.V/Time	5min	10min	15min	20min	30min	45min	1h	2h	3h	4h	5h	6h	8h	10h	20h
1.85V/cell	172.1	136.7	117.4	99.2	79.7	60.9	50.0	32.1	25.5	20.9	16.9	14.7	12.0	10.3	5.61
1.80V/cell	228.6	172.6	140.0	115.6	92.7	70.2	55.7	34.8	27.2	22.2	18.0	15.7	12.7	10.9	5.66
1.75V/cell	252.2	186.6	151.0	123.1	95.4	72.2	58.0	35.9	27.6	22.6	18.4	16.1	12.9	11.0	5.70
1.70V/cell	270.0	198.8	159.0	128.4	98.7	74.8	59.7	37.3	28.4	23.1	18.9	16.4	13.0	11.1	5.81
1.65V/cell	293.6	212.6	167.8	135.4	103.3	76.0	61.2	38.1	29.4	23.8	19.3	16.7	13.2	11.3	5.88
1.60V/cell	316.3	225.5	176.5	142.7	108.3	78.8	63.1	39.2	30.2	24.5	19.9	17.0	13.3	11.4	5.90

Specifications subject to change without notice.

Dimensions

T6 Terminal Unit: mm

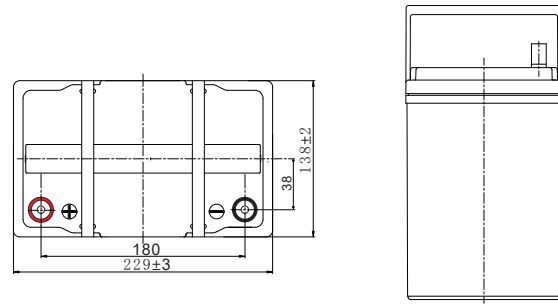
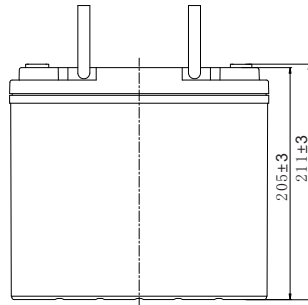
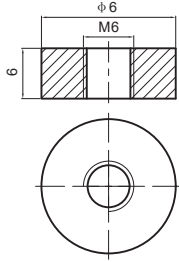

Discharge Characteristics

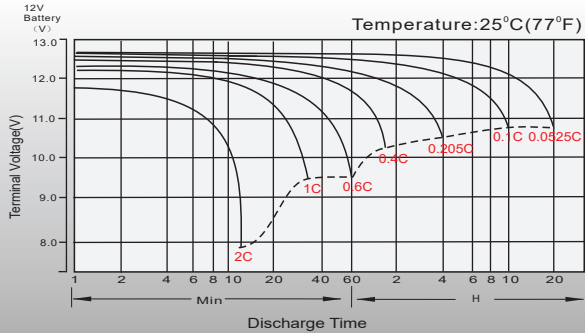

Float Charging Characteristics

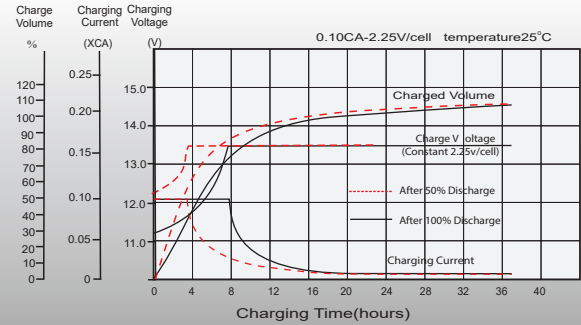

Temperature Effects in Relation to Battery Capacity

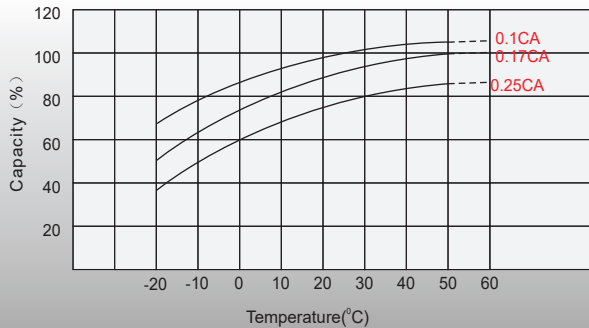

Effect of Temperature on Long Term Float Life

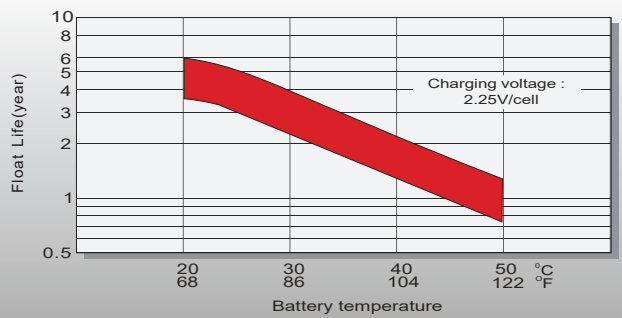

Cycle Life in Relation to Depth of Discharge

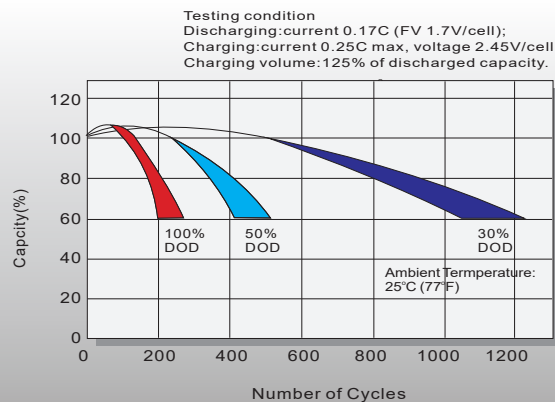

Self Discharge Characteristics

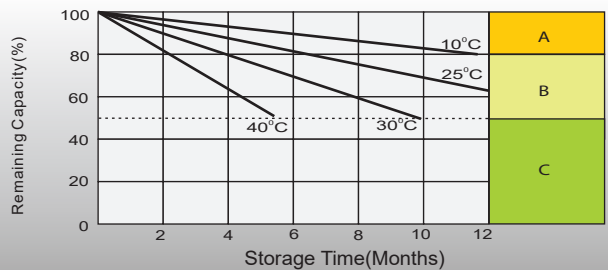

- A** No supplementary charge required
(Carry out supplementary charge before use if 100% capacity is required.)
- B** Supplementary charge required before use. Optional charging way as below:
1. Charged for above 3 days at limited current 0.25CA and constant voltage 2.25V/cell.
2. Charged for above 20 hours at limited current 0.25CA and constant voltage 2.45V/cell.
3. Charged for 8-10 hours at limited current 0.05CA.
- C** Supplementary charge may often fail to recover the capacity.
The battery should never be left standing till this is reached.